

Itabar Pitot Tube-FTN

Technical data

Threaded process connection
PN16-PN40-150-300lbs
DN40-DN1800 11/2"-72"
Sensor Sizes: 20/25/35
T max.: 450°C / 842F
End support as an option
Sensor material: AISI 316Ti
Retraction via chain

Drawings for FTN

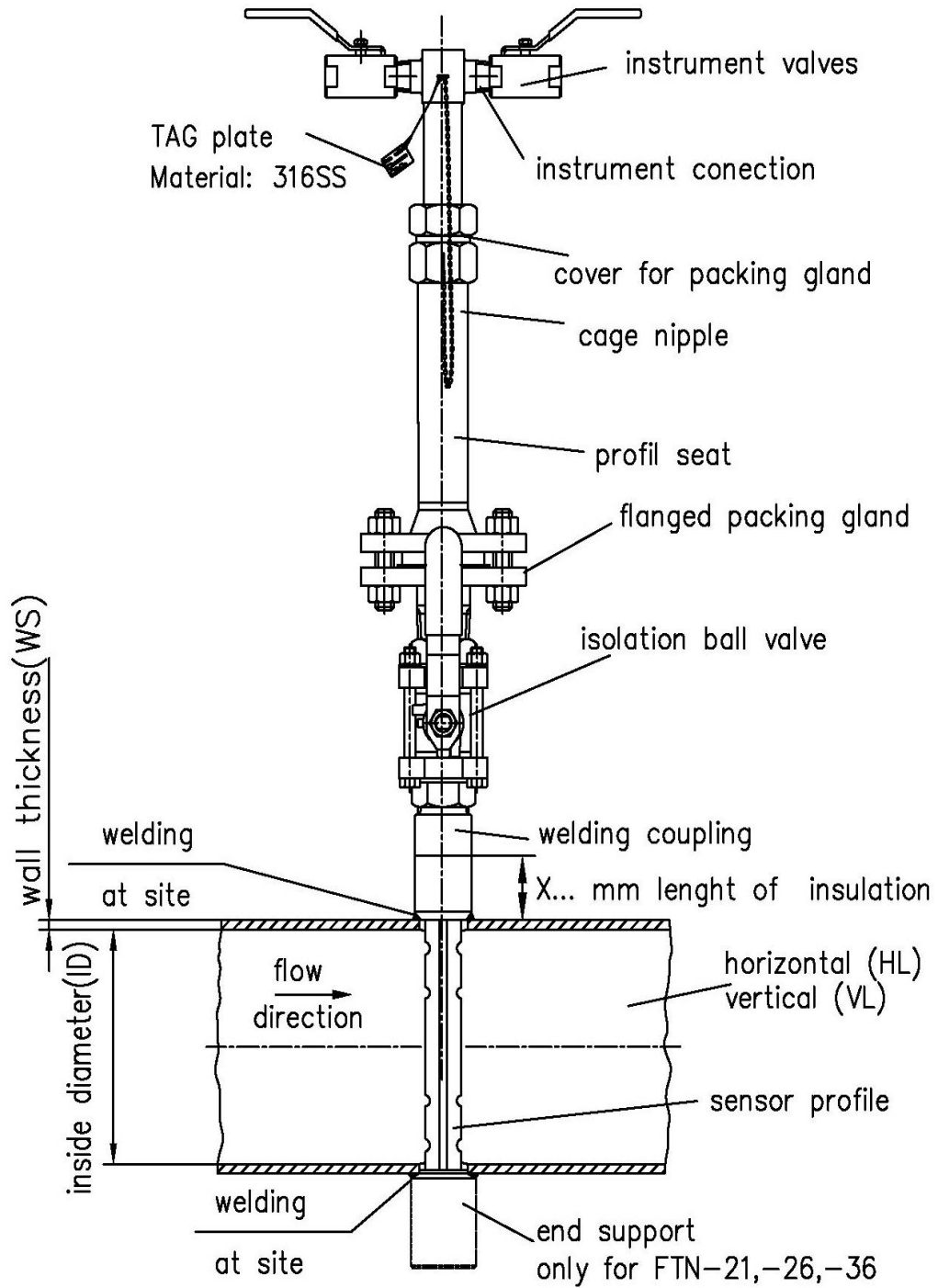

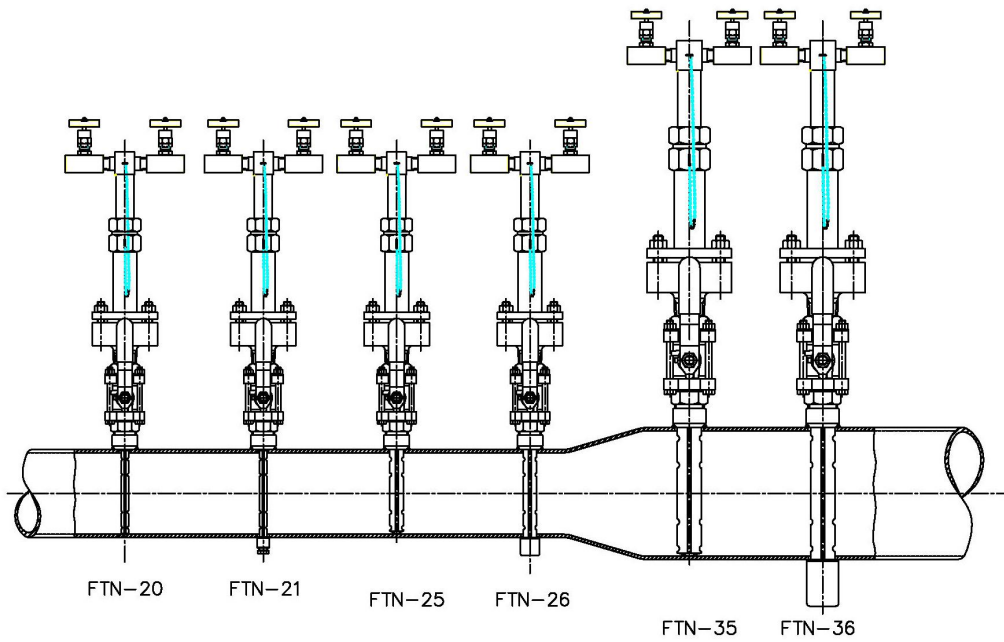

Pipe diameter		Maximum allowable volumetric flow in m ³ /h					
		Sensor type					
Inches.....mm		FTN -20	FTN -21	FTN -25	FTN -26	FTN -35	FTN -36
1 1/2	DN 40	40	114	---	---	---	---
2	DN 50	59	161	---	---	---	---
2 1/4	DN 65	93	243	---	---	---	---
3	DN 80	130	328	---	---	---	---
4	DN 100	179	439	205	544	---	---
5	DN 125	---	---	281	719	---	---
6	DN 150	---	---	358	894	---	---
8	DN 200	---	---	515	1242	---	---
10	DN 250	---	---	687	1623	---	---
12	DN 300	---	---	872	2034	1757	4204
14	DN 350	---	---	1053	2433	2142	5067
16	DN 400	---	---	1226	2828	2532	5938
20	DN 500	---	---	1592	3627	3283	7611
24	DN 600	---	---	1949	4423	4052	9327
28	DN 700	---	---	2318	5237	4851	11106
32	DN 800	---	---	2704	6099	5667	12930
36	DN 900	---	---	---	7000	---	14790
40	DN 1000	---	---	---	7921	---	16614
48	DN 1200	---	---	---	9763	---	20450

56	DN 1400	---	---	---	---	---	24220
64	DN 1600	---	---	---	---	---	27987
72	DN 1800	---	---	---	---	---	31613
80	DN2000	---	---	---	---	---	---